



INSTALLATION - MAINTENANCE MANUAL F15 and F30 Series 150 and 300 Lb. Flanged Full Port Ball Valves

DESIGN

The design features of this valve include a split body, two piece construction, allowing ease of maintenance without special tools. These valves feature a "free floating" ball. The ball is not fixed, but is free to move with the line pressure.

As a result of this feature, these valves are capable of tight shut-off with flow in either direction or dead-ended, regardless of the position of the valve in the line.

The downstream seat, opposite the pressurized side of a closed valve, must carry the load exerted by the line pressure on the ball, while the upstream seat is subject to little load or wear. For this reason, it is sometimes possible to increase useful seat life by turning the valve end-for-end in the pipeline.

1. USE:

The valve should be maintained as part of a preventative maintenance program and in accordance with Flow-Tek's recommended pressure, temperature and corrosion limits to insure a long service life. During shipment, storage, and in operation, the valve should be fully open or fully closed ("open" is preferred for shipping and storage). Do not use in throttling service without investigating flow and pressure conditions.

WARNING: Before installing this equipment, confirm that it is suitable for the intended service.

The identifications tags describe the maximum allowable service conditions for this product.

Be sure that the installation is protected by appropriate pressure control and safety devices to insure that acceptable limits are not exceeded.

2. OPERATION:

Operation of the valve is done by turning the handle a 1/4 turn (90 degree turn). CW to close, CCW to open.

A. VALVE OPEN POSITION

The handle is parallel with the pipeline.

B. VALVE IN CLOSED POSITION

The handle is perpendicular to the pipeline.

Valves with actuators should be checked for actuator -valve alignment. Misalignment will result in high operational torque and damage to valve stem and seals.

3. STEM SEAL ADJUSTMENT

1. For 1/2" - 2", if slight leakage is noted at stem, straighten lock washer tab, tighten stem nut to flatten Bellville Washers, back stem nut off 1/4 turn, secure lock washer tab.
2. For sizes larger than 2", simply tighten gland bolts evenly until leak stops. Do not over tighten.

4. GENERAL INFORMATION FOR ON-SITE INSTALLATION:

The valve may be fitted in any position on the pipeline.

Before installing the valves, the pipes must be flushed clean of dirt, burrs, and welding residues, or the seats and ball surface will be damaged.

5. DISASSEMBLY AND CLEANING PROCEDURE:

CAUTION: Line must be depressurized before disassembly. Valve should be cycled to assure there is no pressure is trapped in valve cavity. Ball valves can trap pressurized media when closed. Flush line with valve 1/2 open to remove hazardous media.

WARNING: DO NOT remove packing gland or any other valve parts while line is under pressure!

Stem seal leakage may be corrected without disassembly by tightening the packing gland nut until such leakage stops. If the leakage continues or valve operating torque becomes excessive, the seals are worn and replacement will be necessary.

If the valve has been used to control hazardous media, it must be decontaminated before disassembly.

It is recommended that the following steps be taken for safe removal and assembly.



As shipped from the factory, Valves contain Silicone based lubricant. This is for break-in and may be removed by disassembly and solvent washing, if it is objectionable for a particular application,

6. DISASSEMBLY FOR STEM AND SEAL REMOVAL:

1. Remove flange bolts and nuts and lift valve from line for servicing.

NOTE: Care should be taken to avoid scratching or damaging serrated flange face. These valves are heavy!

They should be adequately supported before removal from the line is begun.

2. Loosen handle set screw and remove handle and stop plate. Next, remove gland nuts, gland flange and gland.
3. Remove body end nuts, using proper wrench size. Lift off body end. One seat should come out with body end.
4. Remove body seal.
5. To take out the ball, rotate stem so ball is in fully closed position. Lift ball from body, using a strap and lift device, if necessary. **NOTE: Extreme caution should be taken to avoid damage to the ball.**
6. Take out other seat.
7. Stem must be removed from inside the body - a tap on the top of the stem should loosen it. The thrust washer should come out with the stem. Then remove the stem packing.

7. VISUAL INSPECTION:

Clean and inspect metal parts. It is not necessary to replace the ball and stem unless the seating surfaces have been damaged by abrasion or corrosion. We strongly recommend replacement of all soft parts whenever the valve is disassembled for reconditioning.

This is the surest protection against subsequent leakage after valve assembly. The replacement parts can be ordered in kit form.

NOTE: The valve may be assembled and operated

dry where no lubricants are allowed in the system; however, a light

lubrication of mating parts will aid in assembly and reduce initial operating torque. Lubricant used must be compatible with the intended line fluid.

8. ASSEMBLY:

1. Install one seat in the body seat cavity with the spherical curvature facing the ball.
2. Install thrust washer on stem and slide the stem up through the body. Install packing and packing gland with packing gland bolt.
3. Install stop plate, handle and handle retainer nut.
4. Turn the handle CW to the CLOSED position. Line up the ball slot with the stem tang and slide the ball into position. Turn the handle CCW to the OPEN position to hold the ball in place.
5. Install the remaining seat into end cap seat pocket
6. Put body seal gasket into shoulder counter bore at flange in valve body.
7. Put end cap back into body and line up end flange. Because the body flange bolt pattern is different from the line flange bolt pattern, it is possible to assemble the valve which the bolt holes in the line flanges don't line up. Be certain to align end flanges bolt holes to straddle valve center lines.

NOTE: Be careful not to damage body seal when assembling end into body.

8. Install body end nuts and tighten in a crossing pattern to the torque specified in Table 1.
9. **WARNING: Extreme care must be exercised during adjustment of body stud nuts to make sure that body studs are fully engaged. There should be at least one stud thread exposed beyond the flange on the body side and beyond the nut on the cap side.**



10. Cycle the valve slowly, with a gentle back and forth motion, to build gradually to the full quarter turn. By cycling slowly, the seat lips will assume a permanent seal shape against the ball. A fast turning motion, at this point, may cut the seats before they have a chance to form the proper seal.
11. Test valve, if possible, prior to placing valve back into line position. **WARNING: If not properly secured, the valve can separate from the pressure source, resulting in possible injury. Always join the valve to companion.**
12. flanges of same pressure rating as valve and secure with a full set of flange bolts.

Table 1

BODY BOLT TORQUE		
VALVE SIZE	F15 (lb.in.)	F30 (lb.in.)
1/2"	140	140
3/4"	140	140
1"	210	210
1 1/4"	210	210
1-1/2"	550	550
2	550	550
2-1/2"	550	550
3"	550	1000
4"	550	1000
6"	1000	1000
8"	1000	1450
10"	1450	2400
12"	1450	3600

TEST AS FOLLOWS

1. Secure valve to a test future by means of a mating flange with full bolting and a suitable gasket. Orient valve so seat to he tested is facing up.
2. Introduce 50 to 100 psig air. Partially cycle the valve, under pressure, and then slowly close to make sure the cavity is pressurized (use hearing protection). Pour water into the upper port to cover the ball and visually check for bubbles. If bubbles appear,

pour the water out, cycle the valve several times and recheck. To check for leakage in the other port, reverse the valve and introduce air pressure to the port just checked.

3. Check stem seal at this time by coating the gland area with a soapy water solution. If leakage occurs, tighten stem seal just until leakage stops.

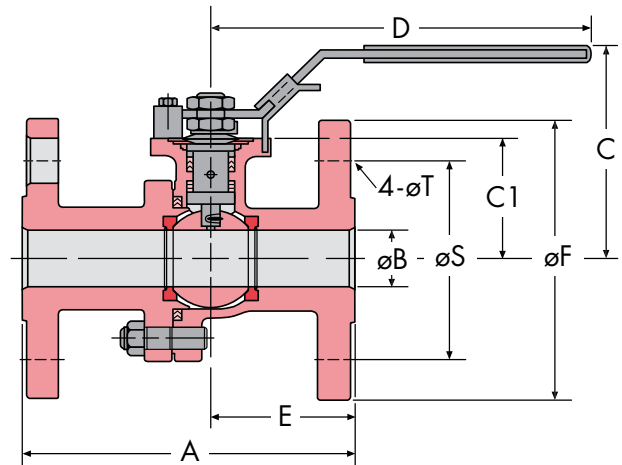

SECTION VIEW 1/2" - 2" VALVES

Dimensions may be found in product literature

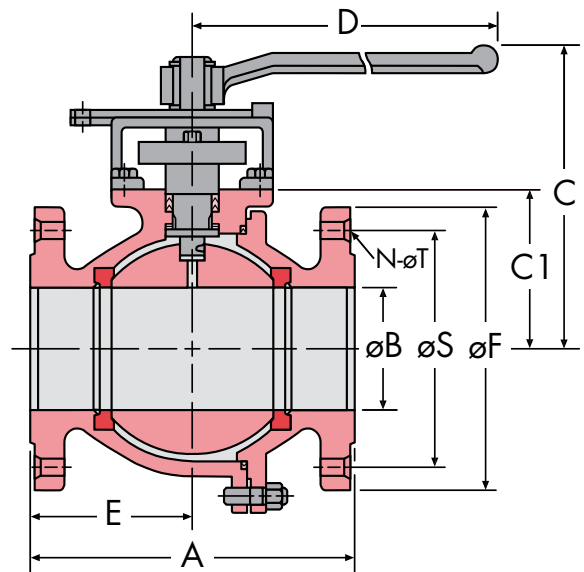

SECTION VIEW 2-1/2" - 12" VALVES



Item	Name
1	Body
2	End Cap
3	Ball
4	Seat
5	Stem
6	Body Seal
8	Body Nut
9	Body Stud
10	Anti-Static Device
11 A	Packing Protector
11 B	Thrust Washer Protector
12	Thrust Washer
13	Stem Bearing
14	Stem Packing
15	Packing Gland
16	Packing Follower
17	Gland Bolt
18	Belleville Washer
19	Tab Lock Washer
20	Travel Stop Housing
21	Housing Bolt
22	Travel Stop
23	Travel Stop Sleeve
24	Travel Stop Bolt
25	Handle
26	Lock Nut
27	Handle Bolt
28	Handle Sleeve
29	Locking Device
30	Snap Ring

2 1/2" - 12" Valves

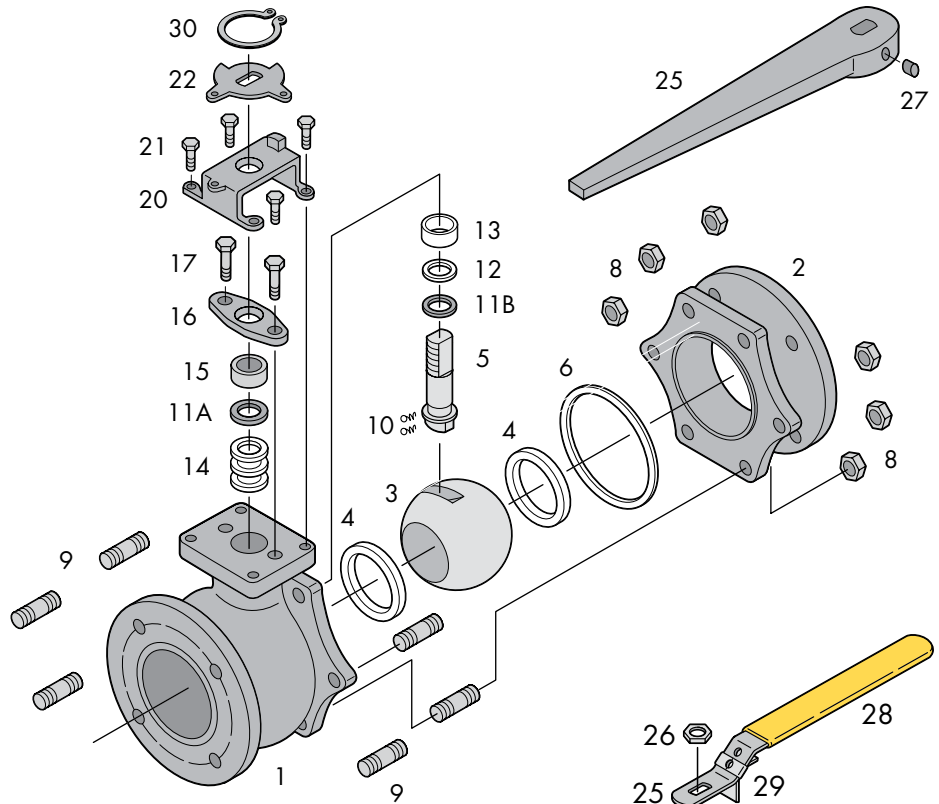

1/2" - 2" Valves

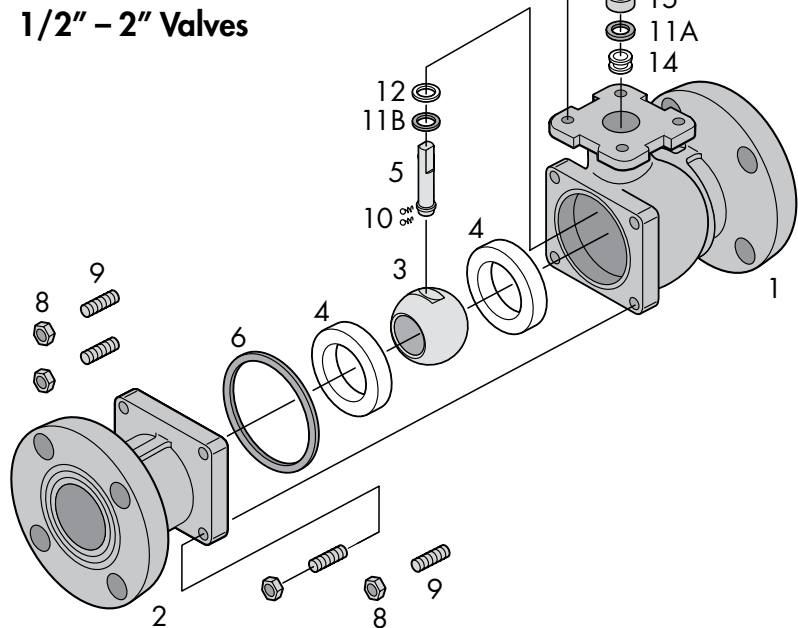



9. SHORT AND LONG TERM STORAGE:

SHORT TERM:

1. Short term storage is defined as storage of products and equipment to be used in the construction of a project for periods of one to three months.
2. Ball valves should remain in the original shipping containers be placed on pallets of wood or other suitable materials. End protectors should remain on the valve ends to prevent the entrance of dirt.
3. Valves should be stored in the open position to protect the ball and seats.
4. Storage of ball valves can be in an open uncovered area provided provisions are made for inclement weather such as tarps or sheeting. Valves with electric actuators shall be stored under cover until ready for installation.

LONG TERM:

1. Long term storage is storage of products and/or equipment for periods of three months or more.
1. Valves should be stored in the open position to protect the ball and seats.
2. Ball valves should remain in the original shipping containers placed on pallets of wood or other suitable materials and stored indoors. End protectors should remain on the valve ends to prevent the entrance of dirt. The storage environment should be dry and not have severe swings in temperature and humidity.

10. SAETY TIPS AND WARNINGS

1. Before installation confirm that valve is suitable for the intended service.
2. Make sure that line is depressurized and drains are open/monitored during installation
3. Before working on valve being in service make sure that service media has been flushed and line is safe. Make sure that all applicable MSDS sheets are available. Follow all safety related procedures.
4. Before disassembly valve shall be cycled several times to assure there is no pressure trapped in body cavity.
5. During assembly make sure that all threaded connections are safe and have proper engagement.
6. During the pressure test of reassembled valve follow all safety precautions to avoid possible injury. (Use of proper test equipment, correct parts assemblies, follow test procedures)
7. While line is under pressure DO NOT remove packing gland or any other valve parts.